



# UNDERRUN PROT. REV. 2 CATALOGUE 2023



**Ing A.F. Baeder Ges.m.b.H.**

📍 Kolpingstraße 13, 1230 Vienna

☎ +43 (0)1 865 16 40

✉ sales@baeder-automotive.com

🌐 www.baeder-automotive.com



# UNDERRUN PROTECTION ACCORDING TO ECE R58 REV. 2



## Underrun protection aluminium silver anodized - pre-drilled



Underrun protection	Length	Weight	Itemnr.
Beam incl. endplates	2400mm	20,4kg	14 4164 001
Endplates			Itemnr.
Endplate (2x)			15 5394 014
Mud guard			Itemnr.
2400 x 330mm with imprint			91001

The aluminum underrun protection is silver anodized and has a groove. This version is pre-drilled for mounting Aspöck lights and components.

## Underride protection aluminum silver anodized - undrilled



Underrun protection	Length	Weight	Itemnr.
Beam incl. endplates	2400mm	20,4kg	14 4164 301
Endplates			Itemnr.
Endplate (2x)			15 5394 014
Mud guard			Itemnr.
2400 x 330mm with imprint			91001

The aluminum underrun protection is silver anodized and has a groove. This version is undrilled.

## Underride protection aluminum white powder-coated RAL 9010 - pre-drilled



Underrun protection	Length	Weight	Itemnr.
Beam incl. endplates	2400mm	20,4kg	14 4164 021
Endplates			Itemnr.
Endplate (2x)			15 5394 014
Mud guard			Itemnr.
2400 x 330mm with imprint			91001

The aluminum underrun protection is powder-coated in white and has a groove. This version is pre-drilled for mounting Aspöck lights and components.

# UNDERRUN PROTECTION ACCORDING TO ECE R58 REV. 2



## UDSP (Underrun Diamond Steel Protection)



Underrun protection	Length	Weight	Itemnr.
UDSP	2412mm	52,9kg	21-580678
Spacers		Weight	Itemnr.
6mm		0,36kg	21-584700
8mm		0,49kg	21-584600
10mm		0,61kg	21-584200
14mm		0,85kg	21-584300
16mm		1,0kg	21-584400

### Matching plate sets

EUP, EUR-4

The stable protective profile made of steel is suitable for plant vehicles. Its design prevents bulk material from collecting on top of the protective profile when it is tipped.

## UHAP-2 (Underrun Hollow Aluminium Profile - Generation 2)



Underrun protection	Length	Weight	Itemnr.
UHAP-2	2400mm	20,0kg	21-210800
UHAP-2 with reflectors	2400mm	20,0kg	21-210700
Mounts		Weight	Itemnr.
universal <sup>1</sup>		1,0kg	21-175000
for EUP, EUR-4, EUF-2 <sup>2</sup>		7,3kg	21-175178

### Matching plate sets

EUH-2, EUT, EUM-2, EUS-4, EUP, EUR-4, EUL, EUS-MFC, UPS-2, UPSO-2, EUF-2

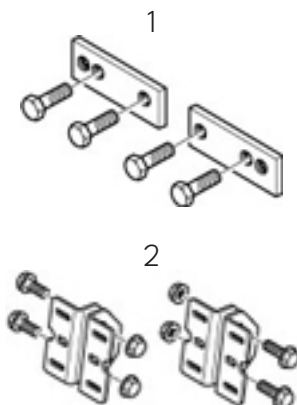

These aluminum trusses are anodized and equipped with holders for dirt traps. A version with attached reflectors for trailers is also available.

# UNDERRUN PROTECTION ACCORDING TO ECE R58 REV. 2



## UOSP (Underrun Open Steel Profile)



Underrun protection	Length	Weight	Itemnr.
UOSP	2358mm	25,5kg	21-176978
Mounts		Weight	Itemnr.
universal <sup>1</sup>		1,7kg	21-178378
for EUP, EUR-4, EUF-2 <sup>2</sup>		7,3kg	21-175178

### Matching plate sets

EUT, EUS-4, EUP, EUR-4, EUS-MFC, UPS-2, UPSO-2, EUF-2

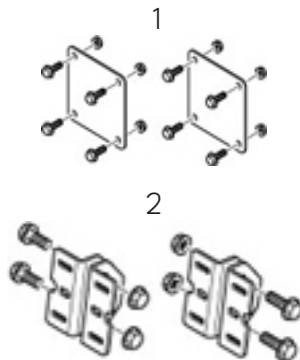

Thanks to its open construction, the protective profile can easily be supplemented with lighting for trucks or trailers.

## UCSP (Underrun Cylindrical Steel Profile)



Underrun protection	Length	Weight	Itemnr.
UCSP Colour Volvo	2314mm	18,0kg	21-177270
UCSP Colour Scania	2314mm	18,0kg	21-177278
Mounts		Weight	Itemnr.
for EUP, EUR-4, EUF-2, UPS-2 and UPSO-2 <sup>1</sup>		10,6kg	21-178478
for EUS-4, EUT, EUL, EUH-3, EUM-3, EUS-MFC <sup>2</sup>		5,7kg	21-183478

### Matching plate sets

EUT, EUP, EUR-4, EUL, EUS, EUS-MFC, UPS-2, UPSO-2, EUF-2

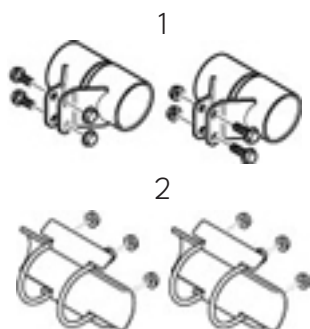

The steel protective profile is suitable for plant vehicles. Its design prevents bulk material from collecting on top of the protective profile when it is tipped.

# UNDERRUN PROTECTION ACCORDING TO ECE R58 REV. 2



## UHAP-2 (Underrun Hollow Aluminium Profile - Generation 2)

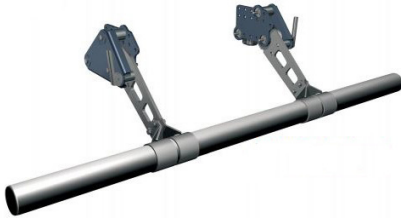

Underrun protection	Weight	Itemnr.
undrilled	65,0kg	14 996 500
MAN	65,0kg	14 996 600
Mercedes	65,0kg	14 996 700

The practical and light protective profile made of steel is suitable for plant vehicles. The design of the protective profile prevents bulk material from collecting on top of the protective profile when it is tilted.

The steel trusses are supplied as standard with a zinc-manganese-phosphate primer and a top coat with a high-quality finish and good corrosion resistance.

## EUFA (Endplate Underrun Protection Foldable and Adjustable)



Underrun protection	Weight	Itemnr.
Iveco	74,9kg	21-590278
Volvo/RVI	76,9kg	21-590378
Scania/Mercedes	75,8kg	21-590478
undrilled	77,4kg	21-590578
Accessories		Itemnr.
Spring kit		21-587578
Mounting tool kit		39-035100

The underrun protection can be integrated into a flexible system for driving with large-volume rigid drawbar trailers. Thanks to the adjustable arm, the height and length of the protective profile can be changed. It makes it easier to fold the underrun protection profiles up and down, for example to reach a coupling that is mounted deep and far to the rear.

# UNDERRUN PROTECTION ACCORDING TO ECE R58 REV. 2



## EU3-3 (foldable underrun protection with round tube)



Underrun protection	Length	Weight	Itemnr.
DAF	400mm	56kg	15 990 200
	550mm	58kg	15 990 188
	650mm	59kg	15 990 194
Iveco	400mm	56kg	15 990 282
	550mm	58kg	15 990 280
	650mm	59kg	15 990 277
Scania, MAN	400mm	56kg	15 990 209
	550mm	58kg	15 990 206
	650mm	59kg	15 990 203
Mercedes	400mm	56kg	15 990 418
	550mm	58kg	15 990 110
	650mm	59kg	15 990 111
Volvo, Renault	400mm	56kg	15 990 197
	550mm	58kg	15 990 191
	650mm	59kg	15 990 176

A simple and inexpensive solution to adapt to the common truck brands. This product is hot-dip galvanized and comes with a round tube. EU3-3 is available in three different arm lengths.

## URSP (Underrun Retractable Steel Protection)



Underrun protection	Length	Weight	Itemnr.
600mm manual	661mm	80kg	21-224600
1000mm manual	1061mm	92kg	21-224700
600mm hydraulic	661mm	92kg	21-192200
1000mm hydraulic	1061mm	101kg	21-192300















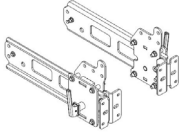



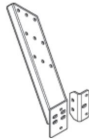
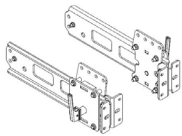



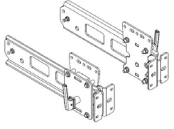



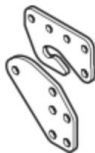

### Matching plate sets

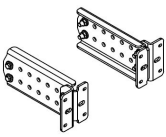
EUH, EUM, EUS, EUT, EUL

With the extendable underrun protection from VBG, the protective profile can be easily and conveniently brought into the desired driving position.

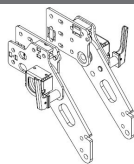
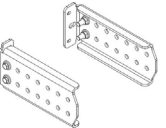
# PLATE SETS



<b>EUH</b> (Assembly on low frame)	<b>EUH-2 DAF</b> 21-227578 	<b>EUM-2 DAF</b> 21-229378 	<b>EUS-4 60</b> 21-225378 	<b>EUT</b> 21-086078 	<b>UPSO-2 60</b> 21-225778 
	<b>EUH-2 IVECO</b> 21-226078 	<b>EUM-2 IVECO</b> 21-227878 	<b>EUS-4 50</b> 21-570778 	<b>EUL</b> 21-186978 	<b>UPSO-2 50</b> 21-571278 
	<b>EUH-2 MAN/MB</b> 21-226978 	<b>EUM-2 MAN/MB</b> 21-228778 	<b>EUS-4 45/60</b> 21-225678 	<b>EUR-4 60</b> 21-215378 	<b>UPSO-2 45/60</b> 21-229678 
	<b>EUH-2 MB</b> 21-226678 	<b>EUM-2 MB</b> 21-228478 	<b>EUS-MFC</b> 21-184678 	<b>EUR-4 50</b> 21-571078 	<b>Mounting on:</b> Vehicle frame, EDS, EDH-2, EDM, EDL, EDK, EDHZ, EDMS-2, EDC-1, EDH-2SKV, EDH- 2SKH, EDK SC, EDH- 3, EDM-2, EDL-2.
	<b>EUH-2 SCANIA</b> 21-226378 	<b>EUM-2 SCANIA</b> 21-228178 	<b>EUP 60</b> H=135 21-212478 H=195 21-212778 	<b>EUR-4 45/50</b> 21-230578 	<b>for UHAP-2</b> 21-230678 
	<b>EUH-2 VOLVO / RVI</b> 21-227278 	<b>EUM-2 VOLVO/RVI</b> 21-229078 	<b>EUP 50</b> H=135 21-570478 H=195 21-570578 	<b>EUH-2</b> le. 21-176578 ri. 21-176678 	<b>for UCSP</b> 21-230778 
	<b>EUH-3 UNPERFORATED</b> 21-592378 	<b>EUM-3 UNPERFORATED</b> 21-592678 	<b>EUP 45/60</b> H=135 21-212278 H=195 21-212578 	<b>Accessories</b> Parallel strut 21-179778  Bolt set 21-182400  Arm stop set 21-187778	<b>Mounting on:</b> EUP 60 EUP 50 EUP 45/60 EUH EUM